

AUTOMOTIVE CURRENT TRANSDUCER OPEN LOOP TECHNOLOGY

HAH3DR 800-S06



Introduction

The HAH3DR-S06 family is a tri-phase transducer for DC, AC or pulsed currents measurement in high power and low voltage automotive applications. It offers a galvanic separation between the primary circuit (high power) and the secondary circuit (electronic circuit).

The HAH3DR-S06 family gives you the choice of having different current measuring ranges in the same housing (from ± 200 A up to ± 900 A).

Features

- Open Loop transducer using the Hall effect
- Low voltage application
- Unipolar +5 V DC power supply
- Primary current measuring range up to ± 800 A
- Maximum RMS primary admissible current: defined by busbar to have $T < +150$ °C
- Operating temperature range: -40 °C $< T < +125$ °C
- Output voltage: full ratio-metric (in sensitivity and offset)
- Unsealed connector.

Special features

- Tri-phase transducer
- Gold plated terminals
- Compression limiters for M4 screw
- Non waterproof connector.

Advantages

- Excellent accuracy
- Very good linearity
- Very low thermal offset drift
- Very low thermal sensitivity drift
- High frequency bandwidth
- Non insertion losses
- Very fast delay time.

Automotive applications

- Starter Generators
- Inverters
- HEV application
- EV application
- DC / DC converter.

Principle of HAH3DRW Family

The open loop transducers uses a Hall effect integrated circuit. The magnetic flux density B , contributing to the rise of the Hall voltage, is generated by the primary current I_p to be measured.

The current to be measured I_p is supplied by a current source i.e. battery or generator (Figure 1).

Within the linear region of the hysteresis cycle, B is proportional to:

$$B(I_p) = a \times I_p$$

The Hall voltage is thus expressed by:

$$U_H = (c_H / d) \times I_H \times a \times I_p$$

Except for I_p , all terms of this equation are constant. Therefore:

$$U_H = b \times I_p$$

a constant

b constant

c_H Hall coefficient

d thickness of the Hall plate

I_H current across the Hall plates

The measurement signal U_H amplified to supply the user output voltage or current.

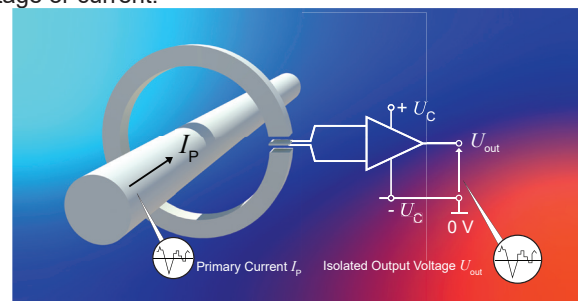
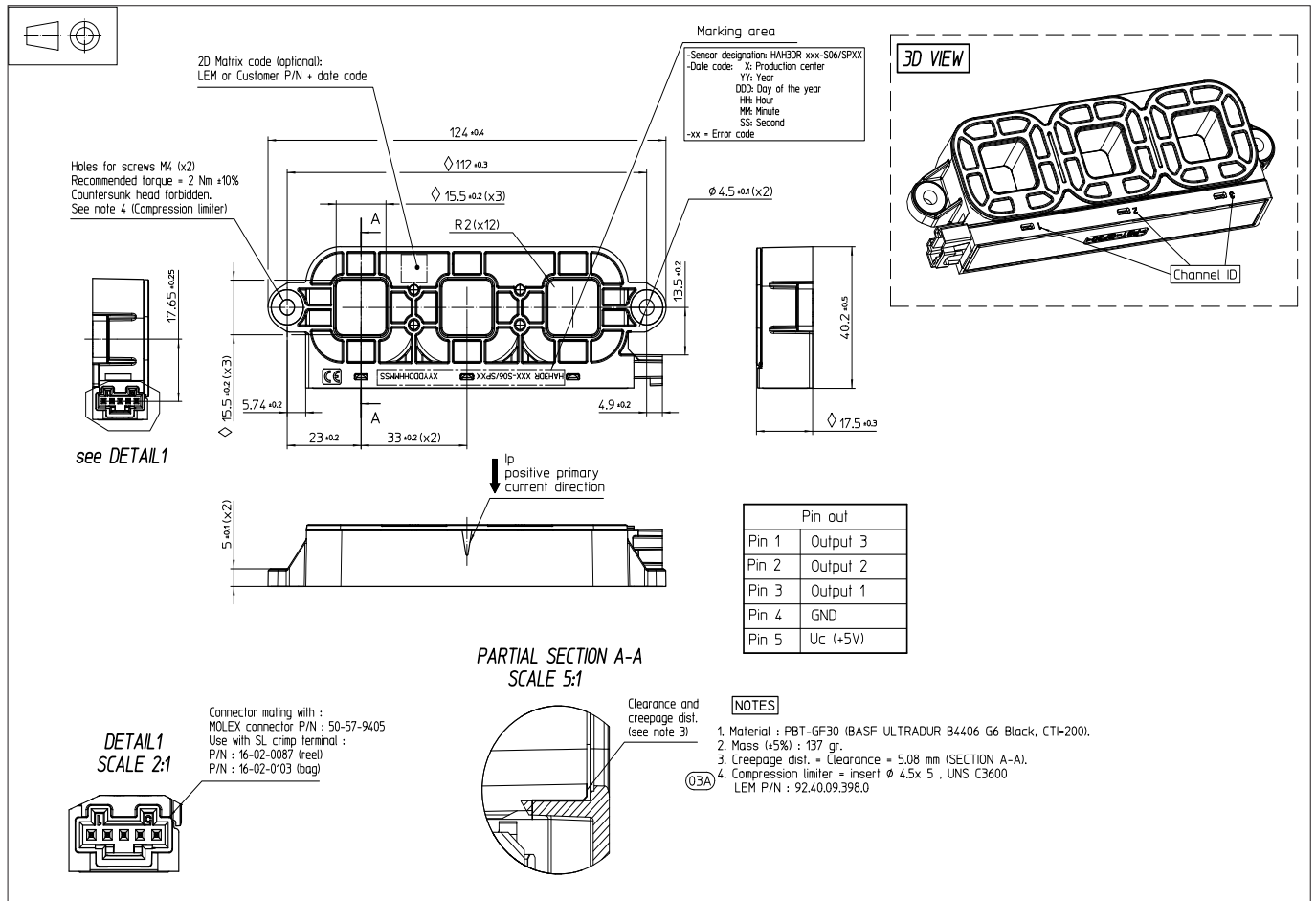

Fig. 1: Principle of the open loop transducer.

Dimensions (in mm)



Mechanical characteristics

- Plastic case >PBT-GF30< (color black)
- Magnetic core FeSi wound core
- Pins Copper alloy gold plated
- Mass 137 g ±5 %
- Degree of protection provided by enclosure IPxx.

Remark

- $U_{out} > U_o$ when I_p flows in the positive direction (see arrow on drawing)

Mounting recommendation

- Connector type Molex 50-57-9405
- Assembly torque max 2 N·m ±10 %
- The clamping force must be applied to the compression limiter, washer recommended.

$R_L > 10 \text{ k}\Omega$ optional resistor for signal line diagnostic
 $C_L < 2.2 \text{ nF}$ EMC protection (optional)
 RC Low pass filter, EMC protections (optional)

Electronic schematic

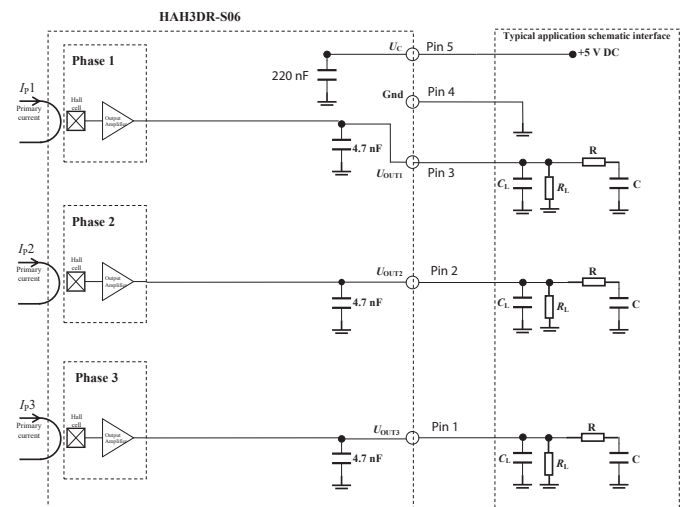

Parameter	Symbol	Unit	Specification			Conditions
			Min	Typical	Max	
Maximum supply voltage	U_{Cmax}	V	-0.5		8	Continuous not operating ³⁾
			-0.5		6.5	Exceeding this voltage may temporarily reconfigure the circuit until next power-on
Ambient storage temperature	T_S	°C	-50		125	
Electrostatic discharge voltage (HBM)	$U_{ESD HBM}$	kV			8	
RMS voltage for AC insulation test, 50 Hz, 1 min	U_d	kV			2.5	50 Hz, 1 min, IEC 60664 part 1
Creepage distance	d_{cp}	mm	5.08			
Clearance	d_{cl}	mm				
Comparative tracking index	CTI		PLC3 (175 V to 249 V)			Typical: 200 V @ 23 °C
Primary nominal peak current	I_{PN}	A			2)	
Insulation resistance	R_{INS}	MΩ	500			500 V DC ISO 16750

Operating characteristics in nominal range (I_{PN})

Parameter	Symbol	Unit	Specification			Conditions
			Min	Typical	Max	
Electrical Data						
Primary current, measuring range	I_{PM}	A	-800		800	
Primary nominal RMS current	I_{PN}	A	-800		800	
Supply voltage ¹⁾	U_C	V	4.75	5	5.25	
Ambient operating temperature	T_A	°C	-40		125	
Capacitive loading	C_L	nF			2.2	
Output voltage (Analog)	U_{out}	V	$U_{out} = (U_C/5) \times (U_o + S \times I_P)$			@ U_C
Sensitivity	S	mV/A		2.5		@ $U_C = 5 V$
Offset voltage	U_o	V		2.5		
Current consumption	I_C	mA		44	50	@ $U_C = 5 V$, @ $-40 °C < T_A < 125 °C$
Load resistance	R_L	kΩ	10			
Output internal resistance	R_{out}	Ω			10	DC to 1 kHz
Performance Data (including phases coupling) ¹⁾						
Ratiometricity error	ε_r	%		0.6		
Sensitivity error	ε_s	%		±1		@ $T_A = 25 °C$, After T Cycles
Electrical offset voltage ⁴⁾	U_{OE}	mV	-6		6	@ $U_C = 5 V$, @ $25 °C$
Electrical offset voltage ⁴⁾	U_{OE}	mV	-13		13	@ $U_C = 5 V$, @ $-40 °C < T_A < 125 °C$
Magnetic offset voltage	U_{OM}	mV	-4.5		4.5	@ $U_C = 5 V$, @ $-40 °C < T_A < 125 °C$
Average temperature coefficient of U_{OE}	TCU_{OEAV}	mV/°C	-0.08		0.08	@ $-40 °C < T_A < 125 °C$
Average temperature coefficient of S	TCS_{AV}	%/°C	-0.04		0.04	@ $-40 °C < T_A < 125 °C$
Linearity error	ε_L	% I_P	-1		1	@ $U_C = 5 V$, @ $T_A = 25 °C$, @ $I = I_{PM}$
Delay time to 90 % I_{PN}	t_{D90}	μs		4	6	$di/dt = 100 A/\mu s$
Frequency bandwidth ²⁾	BW	kHz	40			@ -3 dB
Peak-to-peak noise voltage	$U_{no pp}$	mV			10	@ DC to 1 MHz
Phase shift	$\Delta\phi$	°	-4		0	@ DC to 1 kHz

Notes: ¹⁾ The output voltage U_{out} is fully ratiometric. The offset and sensitivity are dependent on the supply voltage U_C relative to the following formula:

$$I_P = \left(\frac{5}{U_C} \times U_{out} - U_o \right) \times \frac{1}{S} \text{ with } S \text{ in (V/A)}$$

²⁾ Primary current frequencies must be limited in order to avoid excessive heating of the busbar, magnetic core and the ASIC (see feature paragraph in page 1)

³⁾ Transducer is not protected against reverse polarity

⁴⁾ No statistic applied (calibrated parameter).

Total error

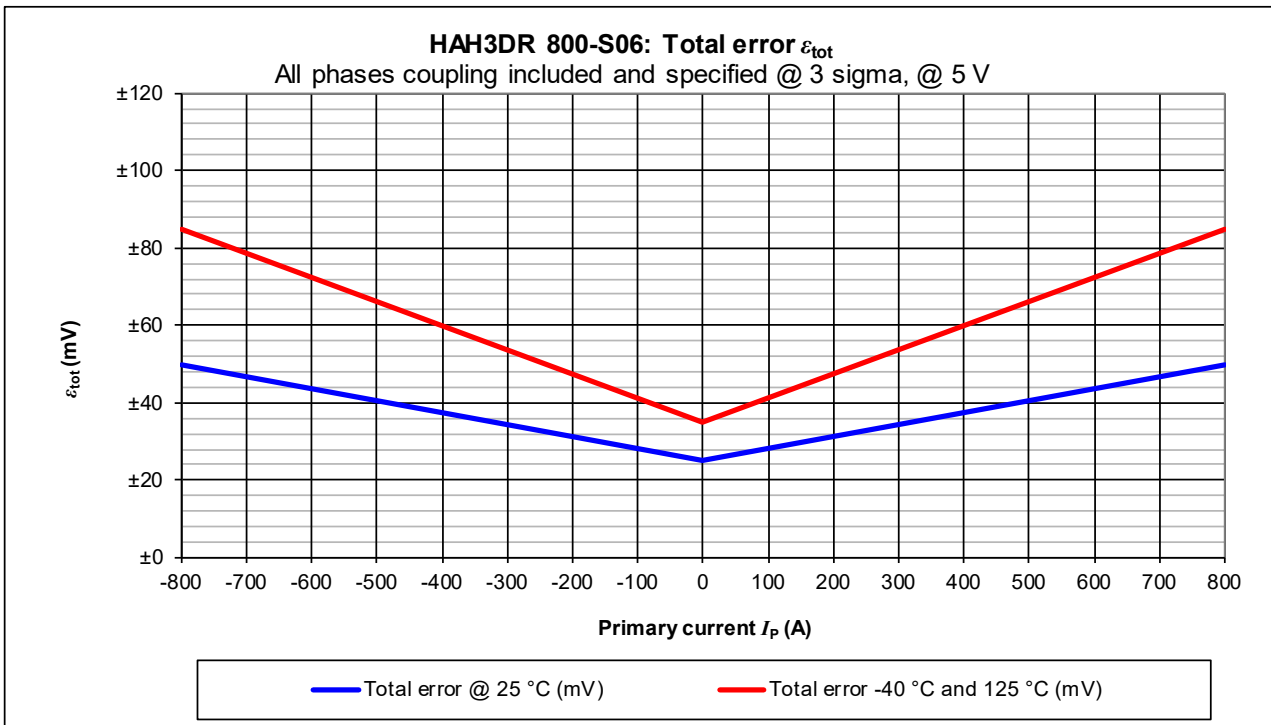

I_p (A)	Total error @ 25 °C (mV)	Total error between -40 °C and 125 °C (mV)
-800	±50	±85
0	±25	±35
800	±50	±85

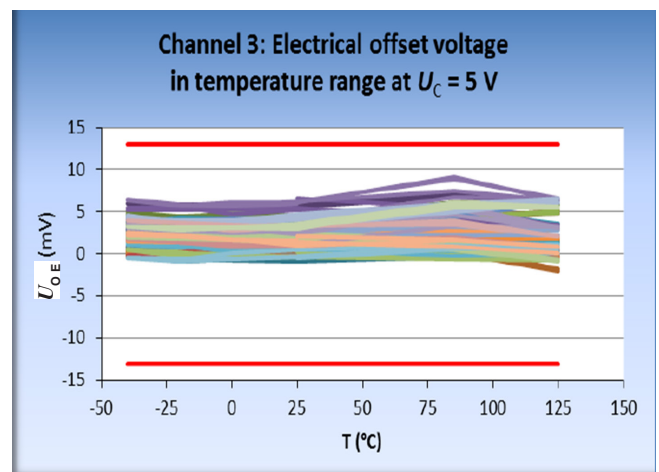
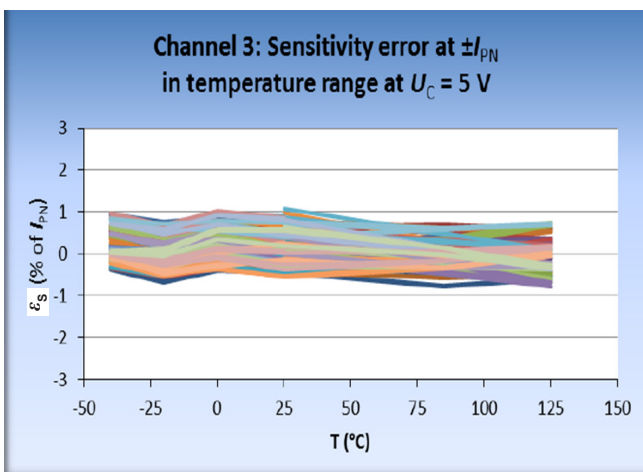
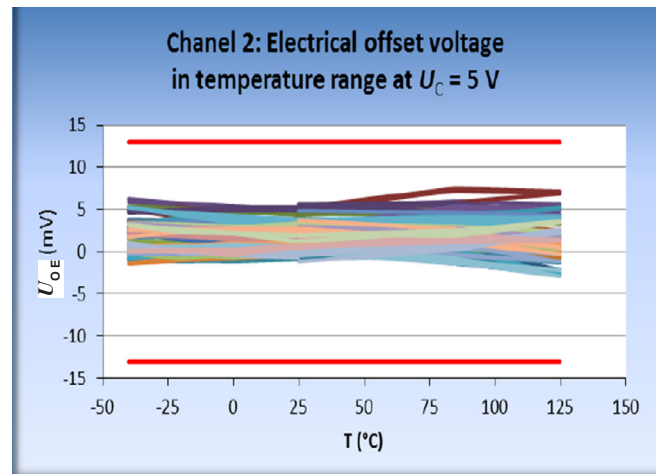
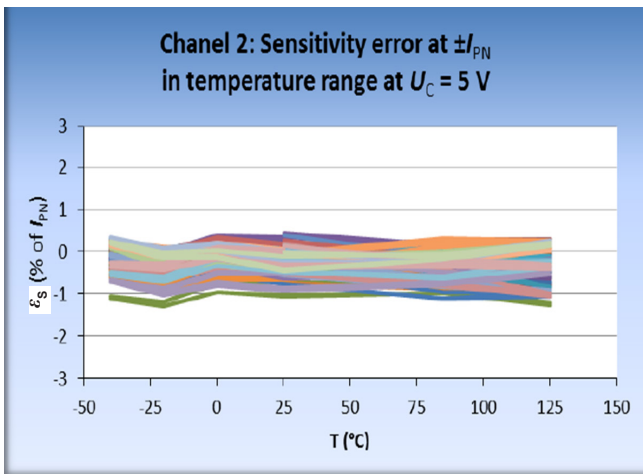
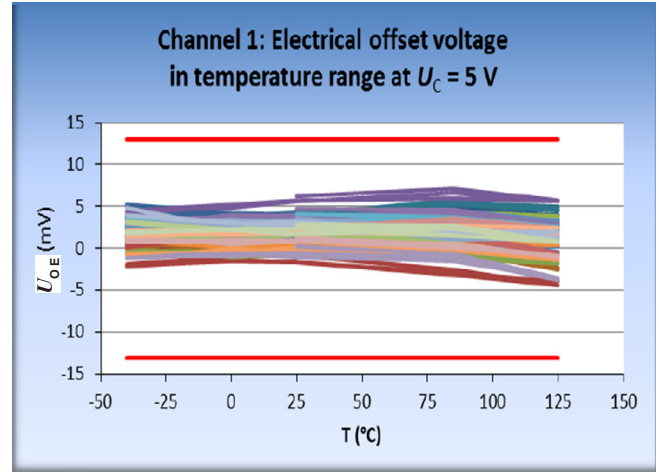
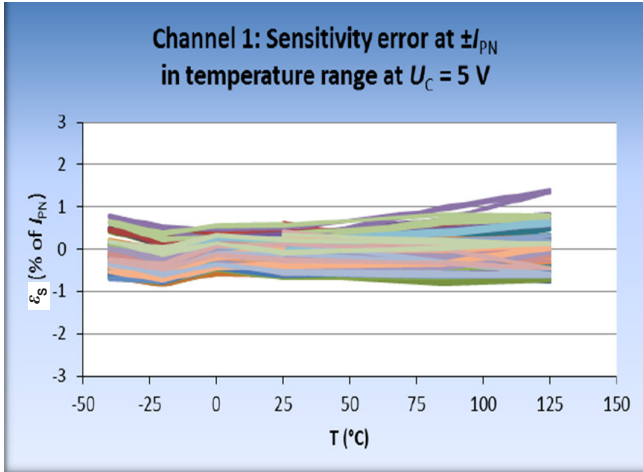

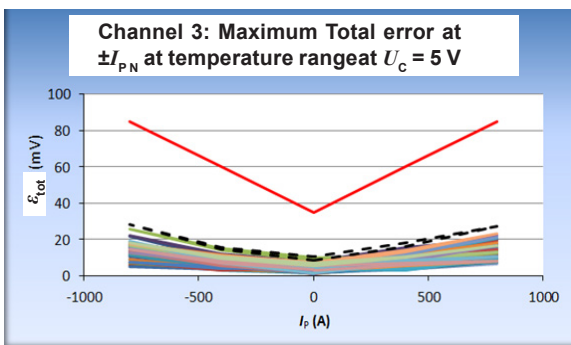
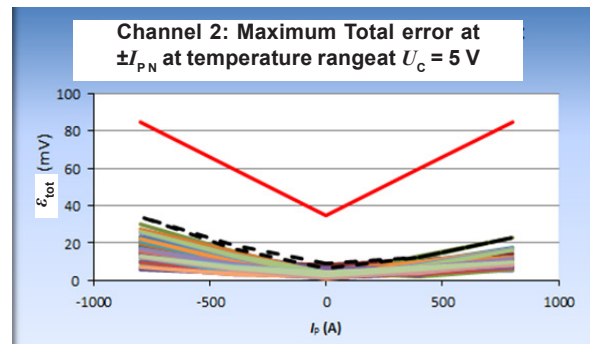
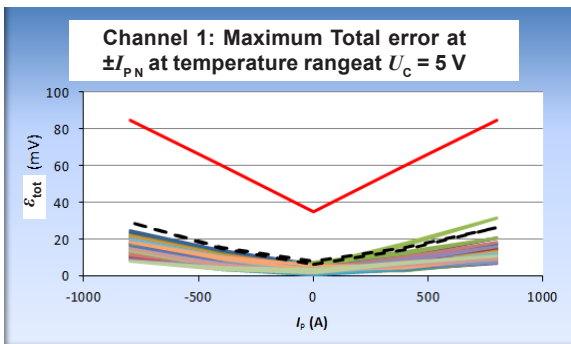
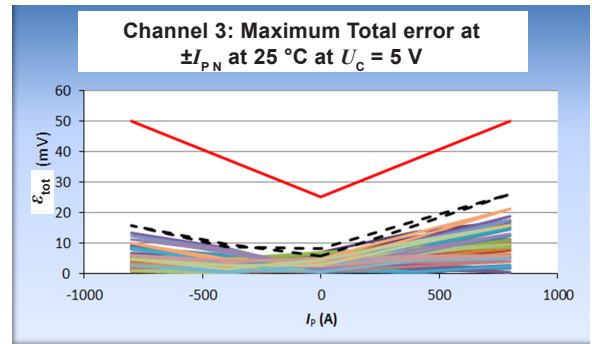
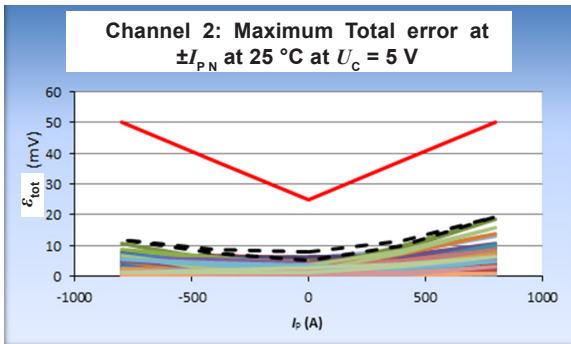
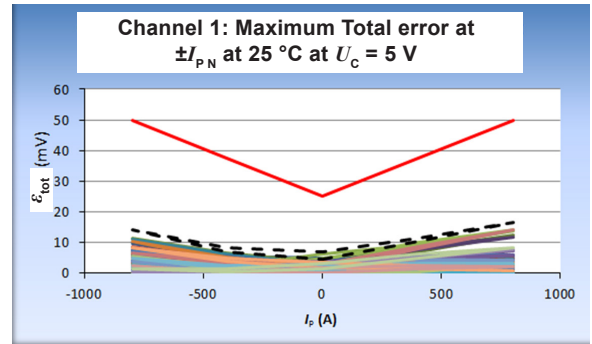
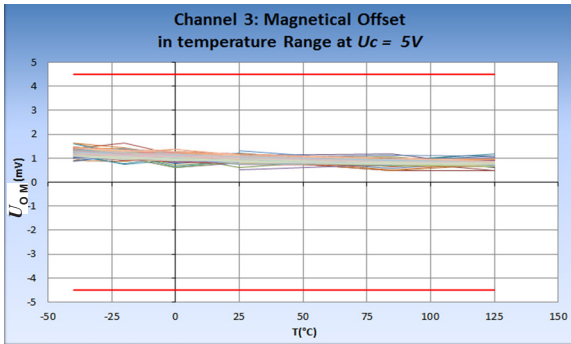
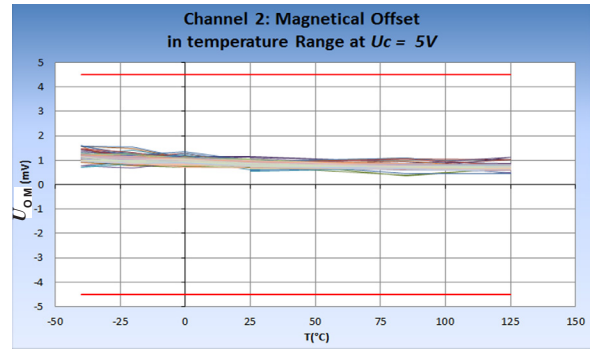
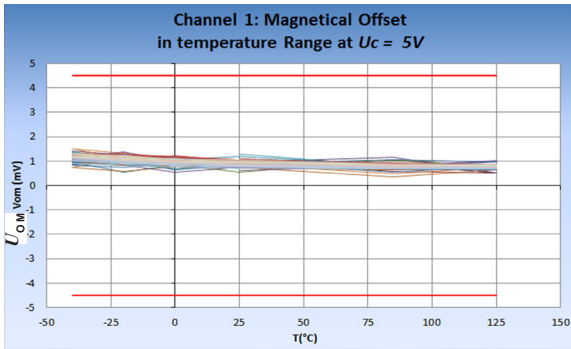

PERFORMANCES PARAMETERS DEFINITIONS

Primary current definition:

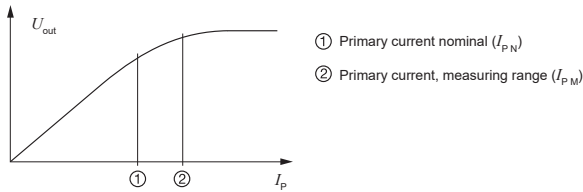

Definition of typical, minimum and maximum values:

Minimum and maximum values for specified limiting and safety conditions have to be understood as such as values shown in "typical" graphs. On the other hand, measured values are part of a statistical distribution that can be specified by an interval with upper and lower limits and a probability for measured values to lie within this interval. Unless otherwise stated (e.g. "100 % tested"), the LEM definition for such intervals designated with "min" and "max" is that the probability for values of samples to lie in this interval is 99.73 %. For a normal (Gaussian) distribution, this corresponds to an interval between -3 sigma and +3 sigma. If "typical" values are not obviously mean or average values, those values are defined to delimit intervals with a probability of 68.27 %, corresponding to an interval between -sigma and +sigma for a normal distribution. Typical, minimum and maximum values are determined during the initial characterization of a product.

Output noise voltage:

The output voltage noise is the result of the noise floor of the Hall elements and the linear amplifier.

Magnetic offset:

The magnetic offset is the consequence of an any current on the primary side. It's defined after a stated excursion of primary current.

Linearity:

The maximum positive or negative discrepancy with a reference straight line $U_{out} = f(I_p)$.
Unit: linearity (%) expressed with full scale of I_{pN} .

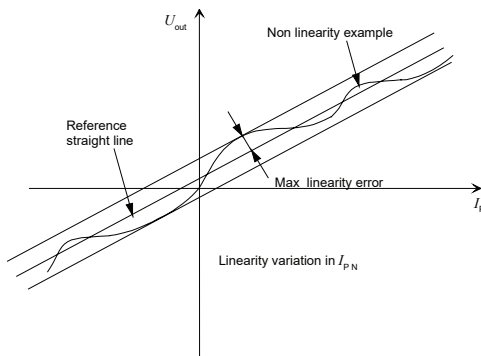

Delay time t_{D90} :

The time between the primary current signal (I_{pN}) and the output signal reach at 90 % of its final value.

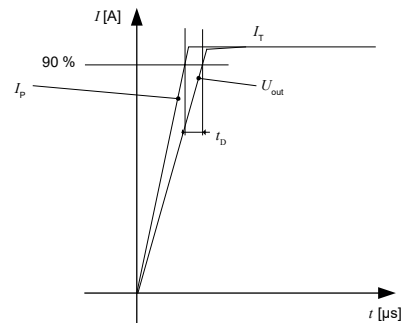

Sensitivity:

The transducer's sensitivity S is the slope of the straight line $U_{out} = f(I_p)$, it must establish the relation:

$$U_{out}(I_p) = U_c/5 (S \times I_p + U_o)$$

Offset with temperature:

The error of the offset in the operating temperature is the variation of the offset in the temperature considered with the initial offset at 25 °C.

The offset variation I_{OT} is a maximum variation the offset in the temperature range:

$$I_{OT} = I_{OE \max} - I_{OE \min}$$

The offset drift $TCI_{OE \text{ AV}}$ is the I_{OT} value divided by the temperature range.

Sensitivity with temperature:

The error of the sensitivity in the operating temperature is the relative variation of sensitivity with the temperature considered with the initial offset at 25 °C.

The sensitivity variation S_T is the maximum variation (in ppm or %) of the sensitivity in the temperature range:
 $S_T = (\text{Sensitivity max} - \text{Sensitivity min}) / \text{Sensitivity at } 25 \text{ }^\circ\text{C}$.

The sensitivity drift TCS_{AV} is the S_T value divided by the temperature range. Deeper and detailed info available is our LEM technical sales offices (www.lem.com).

Offset voltage @ $I_p = 0 \text{ A}$:

The offset voltage is the output voltage when the primary current is zero. The ideal value of U_o is $U_c/2$. So, the difference of $U_o - U_c/2$ is called the total offset voltage error. This offset error can be attributed to the electrical offset (due to the resolution of the ASIC quiescent voltage trimming), the magnetic offset, the thermal drift and the thermal hysteresis. Deeper and detailed info available is our LEM technical sales offices (www.lem.com).

Environmental test specifications:

Refer to LEM GROUP test plan laboratory CO.11.11.515.0 with "Tracking_Test Plan_Auto" sheet.

Recommendations for use:**Storage:**

The LEM transducers must be stored in a dry location, within the following ambient room conditions ($< 40\text{ }^{\circ}\text{C}$ and $< 60\text{ \% RH}$). The product should be stored in its original packing. Ensure during storage and transport, the units are not damaged by applying excess weight to the packaging. Do not stack more than two pallets high. The transducers must not be stored for more than six months.

Unpacking:

When unpacking, care must be taken with cutting tools not to damage the transducer.

Handling:

The LEM transducers must be handled with care and not undergo any shocks or falls (fall = scrap). It is recommended to handle the transducer as long as possible inside its original packing (thermoform tray on customer's assembly station). It is forbidden to handle the transducers by their secondary terminals to avoid problems of ESD. Any rework operations are forbidden and will avoid LEM warranty.

Installation:

The workshop and the people in contact with the transducers must be ESD protected. Before installing, be sure to check that the transducer corresponds to the required application. Be sure that the air gap between the housing of the transducer and the primary bar is sufficient to avoid damage in case of vibrations.

Concerning installation and re-installation, thorough care needs to be taken for taped or screw-mounted sensors.

Sensors fixed by clips must be scraped after any dismantling from the original locations.

- Return busbar effect should be evaluated by the customer in the specific application.
- LEM cannot guarantee transducer accuracy in case of return busbar effect or external magnetic field.

Transducers PV tests plan		
HAH3DR 800-S06		
Initial State	Test Standards	Specific Conditions
Dimensional check	LEM	According to 2D drawing
Visual Inspection	LEM	Pictures
Low temperature wake up	GMW 3172	
Initial temperature characterization	LEM	
Dielectric withstand voltage	Appendix G2.3 Revision Number 0, Sept 2015	2.5 kV, 60 Hz, 1 min, 25 °C
GMW3172 not for GM	Test Standards	Specific Conditions (Thermal Leg until failure)
Thermal shock	Appendix G2.3 Revision Number 0, §5.1	1000 cycles, -40 °C / 125 °C, 60 min / 60 min, power off, change rate around 300°C/min 2000 h
Parametric check	LEM	At 25 °C, 5 V
Withstand voltage test	Appendix G2.3 Revision Number 0, §5.1	2.5 kV, 60 Hz, 1 min, 25 °C
Thermal cycle	Appendix G2.3 Revision Number 0, §5.1	1000 cycles, power off, -40 °C (30 min) to 25 °C (15 min) to 125 °C (30 min) 2000 h
Repeat the Leg 0 until failure		
GMW3172 not for GM	Test Standards	Specific Conditions
Thermal shock	LEM	1000 cycles, -40 °C / 125 °C, 30 min / 30 min, power off, change rate around 300 °C/min
GMW3172 (Shock and vibration)	Test Standards	Specific Conditions
Mechanical shock pothole	Appendix G2.3 Revision Number 0, §5.2	
Parametric check and visual inspection	LEM	At 25 °C, 5 V
Random vibration	Appendix G2.3 Revision Number 0, §5.2	
Parametric check and visual inspection	LEM	At 25 °C, 5 V
Mechanical shock collision	Appendix G2.3 Revision Number 0, §5.2	
GMW3172 85 / 85	Test Standards	Specific Conditions
High temperature, high humidity	Appendix G2.3 Revision Number 0, §5.3	5.1 V, 1000 h, offset monitoring, 85 °C / 85% RH

GMW3172 Electrical test	Test Standards	Specific Conditions
Withstand voltage test	Appendix G2.3 Revision Number 0, §5.4	2.5 kV, 60 Hz, 1 min, 25 °C, (5 mA fault current)
Parametric check and visual inspection	LEM	At 25 °C, 5 V
Isolation resistance	Appendix G2.3 Revision Number 0, §5.4	> 500 Mohms with 500 V DC
Parametric check and visual inspection	LEM	At 25 °C, 5 V
BCI	See GMW 3103 document	§3.4.1 level 2
Radiated Immunity to Magnetic field	See GMW 3103 document	§3.4.5 level 2
ESD, HBM	See GMW 3103 document	C=100 pF, R=1500 ohms, voltage ±2 kV, 3 times to each terminal test setup IEC 61000-4-2
Temperature characterization and free fall on HAH3DR 900-S06	Test Standards	Specific Conditions
Initial temperature characterization	LEM	
Free fall test	ISO 16750-3	3 axis, 2 directions by axis;1 sample per axis; 1 m ; concrete floorLab.
Connector test GMW 3191	Test Standards	Specific Conditions
Terminal push out force	§4.2.5 GMW 3191	
Connector to connector engagement force	§4.2.8 GMW 3191	
Locked connector disengagement force	§4.2.18 GMW 3191	
Unlocked connector disengagement force	§4.2.19 GMW 3191	
Packaging drop test on 1 box	Test Standards	Specific Conditions
Packaging drop test	JIS C60068-2-31	1. Dropping on to a corner test: 4 bottom corners in turn at 10 cm high. 2. Topple test.
Common for al the Legs (except 7 and 8). Final state.	Test Standards	Specific Conditions
Final temperature characterization	LEM	
Dielectric withstand voltage	Appendix G2.3 Revision Number 0, Sept 2015	2.5 kV, 60 Hz, 1 min, 25 °C
Dimensional check	LEM	According to 2D drawing
Visuel Inspection	LEM	Pictures
Cross section	LEM	1 PCBA coming from Leg 1 1 PCBA coming from Leg 3